



Welding Automation PL1100HW Laser Welding System

Integrated Solutions on One Skid

- Servo positioners
- Multiple laser source options
- Choice of process head
- Autogenous laser solutions
- Single 480V electrical disconnect
- Chiller included on separate skid

Manufacturing Safety Enclosure

- Class 1 rating
- No separate structure
- Easy installation
- Optional fume hoods and air filtration available
- Designed to bolt to your floor and produce parts

All From Miller

- The right laser equipment for your application
- Process expertise – see your parts welded before you buy
- Ongoing support
- 24/7 Tech Hotline
- Proven PerformArc reliability
- 1 year warranty



PL1100HW Laser Welding System

Dimensional Specifications*		
Cell length	A	5182 mm (204")
Cell width	B	2896 mm (114")
Cell height	C	2286 mm (90")
Outboard rotation CL from floor	D	1076 mm (42")
Headstock-tailstock span	E	1524 mm (60")
Cell width including doors	F	3118 mm (122")
Fixture rotation diameter	G	864 mm (34")
Cell front opening (max)	H	2591 mm (102")
Penetration distance (stopping calculation)	I	470 mm (19")
Rotation diameter	J	2667 mm (108")
Shipping weight		3357 kg (7400 lb)

*Note: All dimensions are approximate.

Top View

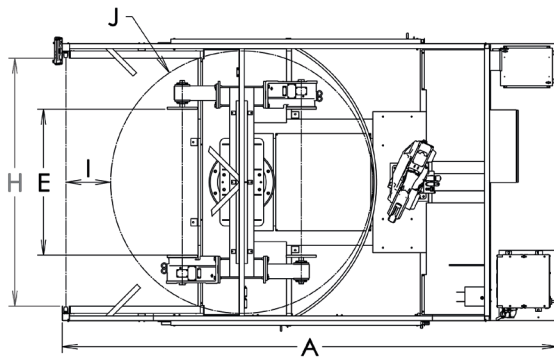

Front View

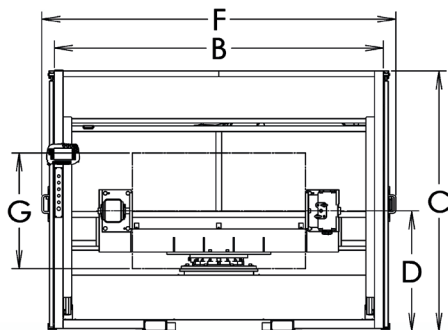

Standard Specifications

Fully Integrated Miller Welding Automation Total Solution Includes:

8 kg arc welding robot
64 bit controller with TFT color display teaching pendant utilizing Windows® CE
High speed main indexing servo positioner
(2) Secondary rotation axis servo positioner 500kg
Fully integrated laser & optics per customer spec
Class I Laser safe-enclosure
Miller designed and manufactured total productivity system
Resume function, shifting function, online help function

Positioner General Technical Specifications

Main sweep axis

Model	Servo Positioner
Motor type	3.5 kW AC Digital Servo
Control type	Servo Control
Rotation time (180 deg index)	t=3.5 sec
Through hole (for utility pass through)	120 mm (4.7")

Secondary axis (2)

Model	500 kg
Motor type	1 kW AC Digital Servo
Control type	Servo Control
Payload (per side)	500 kg (1100 lb)
Payload offset (from positioner CL)	Please consult manual
Through hole (for utility pass through)	55 mm (2.16")

